

All material 22 mm MDF unless specified otherwise

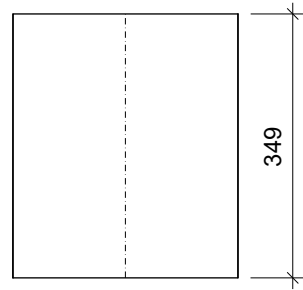

26

TL chamber panel
low section - vertical

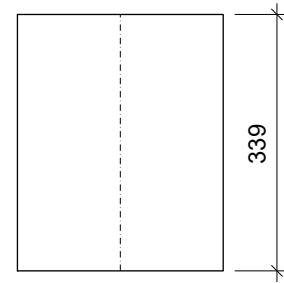

27

TL chamber panel
low section - vertical

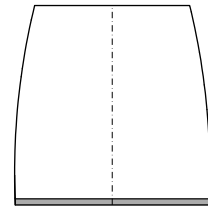

28

TL chamber panel
low section - horizontal

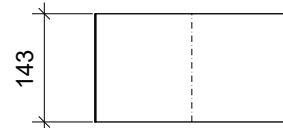

29

Cabinet internal
High section - back panel



30

TL chamber panel
mid section - horizontal

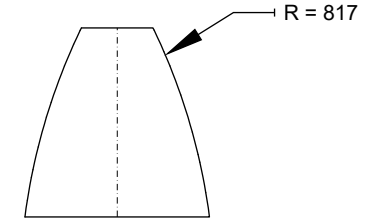

31

TL chamber panel
mid section - horizontal

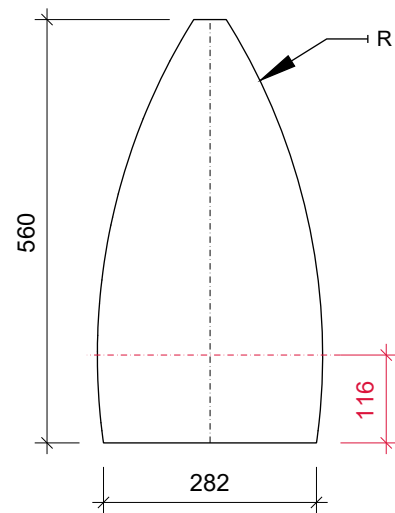

32

Cabinet top
Bottom plate

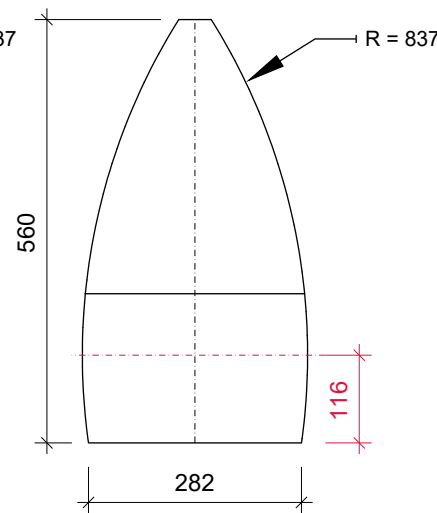

33

Cabinet top
Middle plate

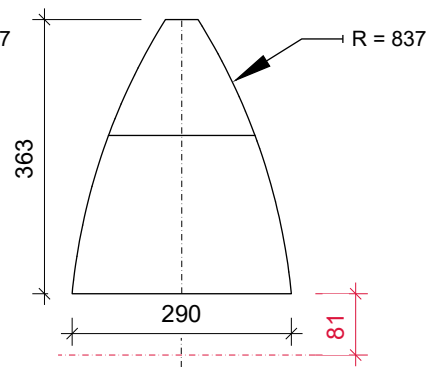

34

Cabinet top
Middle plate

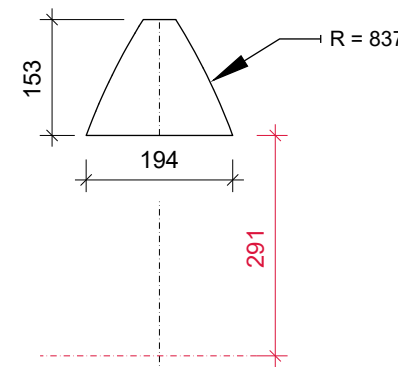

35

Cabinet top
Top plate

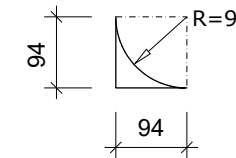
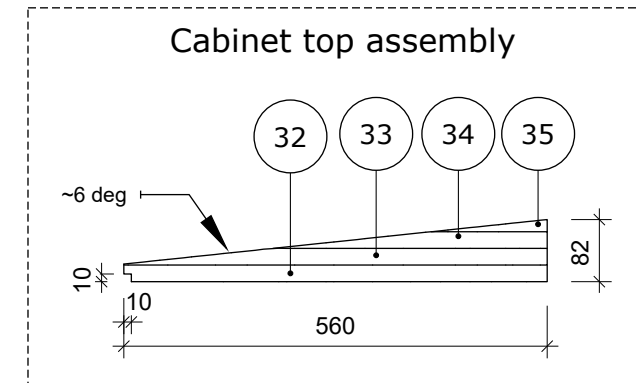

36

Cabinet internal
Corner filler
(~75 pcs/cabinet)

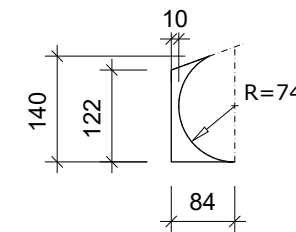

37

Cabinet internal
Corner filler
(~12 pcs/cabinet)

RED dimensions refer to base reference line
(see drawing 09)

None of the constructions, illustrations or information presented here may be used for commercial purposes and cannot be licensed.

Jenzen NEXT
By Troels Gravesen
SEAS CRESCENDO T29CF002 E0040
SEAS W18NX003 E0096-08
SEAS W26FX002 E00601

DATE
19-08-2023

Design modified by:
Ronald van Haaften
The Netherlands

VERSION
<https://www.van-haaften.nl>

v001

DRAWING MADE BY
Ronald van Haaften
DRAWING TITLE
Parts 26:37

A3

13